

OLD LADY 2-8-0

This is a greatly modified version of the Varney "Old Lady". Only the boiler casting, cylinders, and pilot are made from original tooling. The boiler has been changed to accept the DC71 motor in the firebox. The original used DC60 or various imported motors. Many of the other parts will not interchange. Bowser drivers can be used with an old Varney frame but all must be changed and the old gear must be mounted on a Bowser driver.

If the original gear or worm has failed, order all new Bowser drivers plus a #1030 worm.

There is quite a bit of detail on the Old Lady boiler casting and we have no superdetail kit for it. The engine was modeled after a Southern Pacific loco but is similar to locomotives used on the Southern, UP, Erie and other roads. Consult photos of the prototype you wish to model for adding more detail. For available parts see Varney-Bowser Conversion page.

To install an operating head light - drill headlight cast on boiler 3/32" if necessary. Use a Grain of Wheat clear bulb and solder wires to motor brushes.

PILOT COUPLERS- Casey Jones uses Kadee® #4 mounted in pilot coupler pocket with 0-80 screw. Requires drilling & tapping a hole just behind coupler pocket and will not be self-centering.

MOTOR WORM GEAR	
WORM	1030
AXLE GEAR	1021
AXLE SPACING	.820
GEAR RATIO	29-1

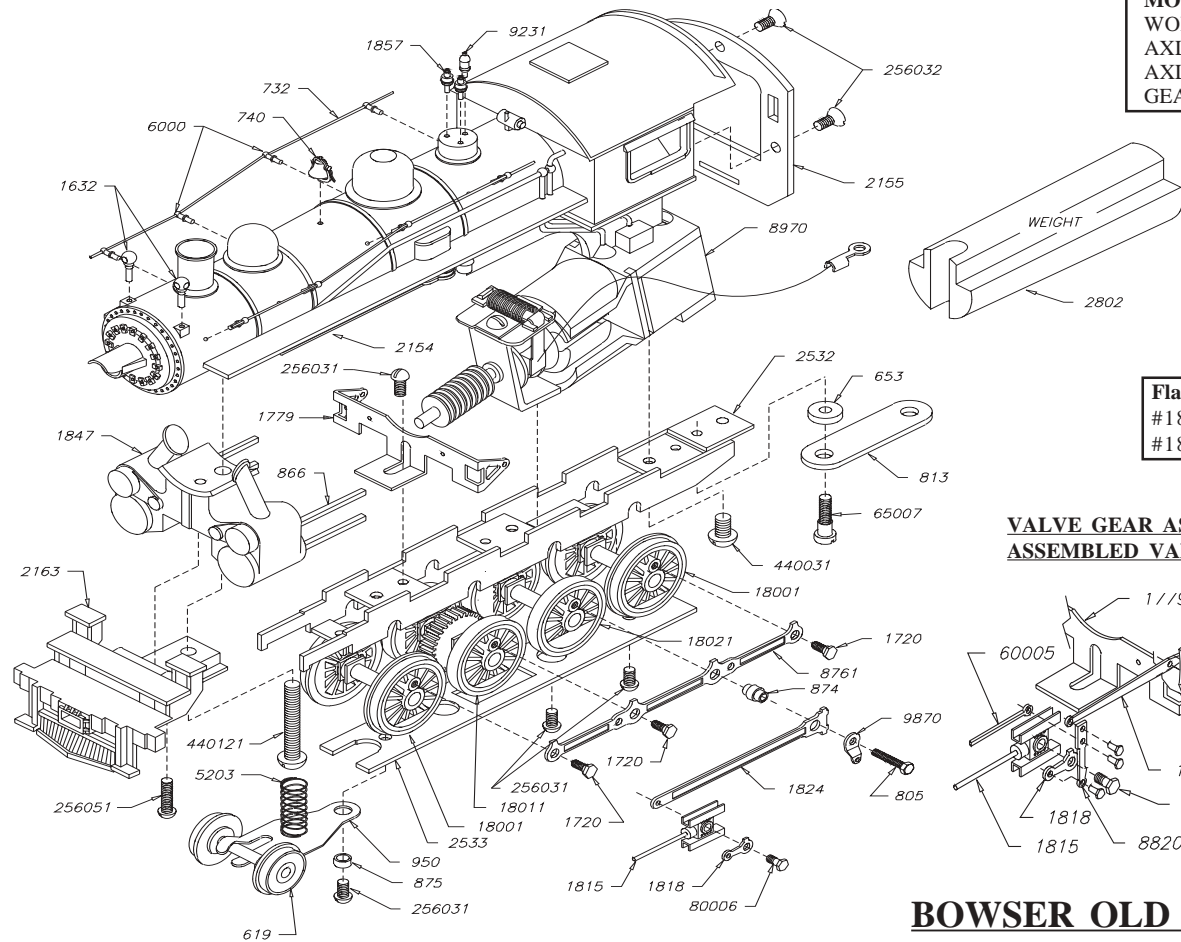

Flanged Drivers	
#18051	62" LT
#18061	62" HVY

VALVE GEAR ASSEMBLY, KIT #100930
ASSEMBLED VALVE GEAR #500930

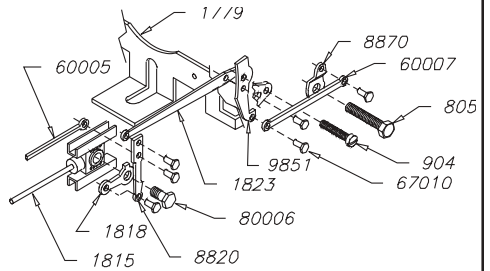

BOWSER OLD LADY **KITS AND ACCESSORIES**

- #100925 Old Lady Consolidation w/ Tender, Kit
- #100932 Painted Engineer and Fireman
- #500930 Assembled Valve Gear

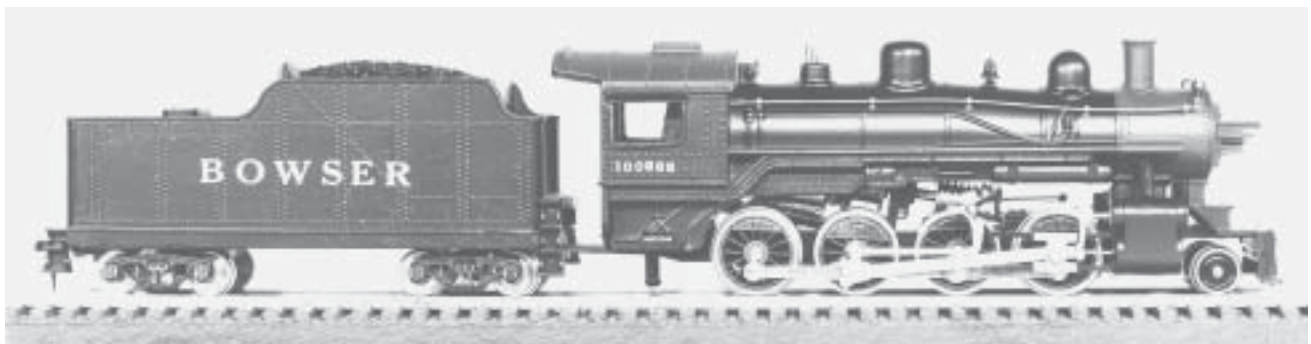

OLDLADY 2-8-0 CONSOLIDATION, PHOTO OF BOWSER MODEL