

MANTUA

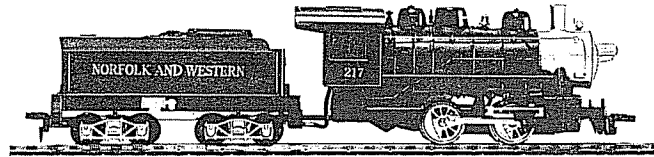

0-4-0 PONY

MECHANISM ASSEMBLY

1. Check all parts with replacement parts list. Study drawing to identify the parts. Read instructions through before starting assembly. Remove all flash and burrs from castings with a knife or fine file.
2. Assemble one No.6301 Long Axle Bearing and two No. 6302 Short Axle Bearings in No.3252 Main Frame, making certain they are properly seated in the slots.
3. Place one pair No.25153 Drivers with Gear in the front or first bearing and one pair No.25150 Drivers in the second or rear bearings. ALL INSULATED WHEELS must be on the left hand side as indicated on the drawing. Insulated wheels are identified by a white ring between the wheel casting and the wheel rim.
4. Place No.3994 Retainer Plate in position and secure with two No.7152 Screws, #2-56x3/16" R.H.S.T. Make certain that each pair of Wheels revolve freely in its bearing.
5. Assemble one No.6821 Side Rod and one No.6390 Main Rod Spacer on drivers with one No.7165 Long Side Rod Screw through large end section of Side Rod in Rear Driver and one No.7159 Short Side Rod Screw through small end section of Side Rod in Front Driver in position designated on drawing. Use No.5511 #0-80 Socket Wrench to tighten screws. DO NOT USE PLIERS. Drawings show left side of assembly. Assemble the right side in the same manner.
6. Check rotation of Coupled Drivers. Tight spots in Side Rods may be freed by reaming slightly with a round needle file. Do not ream any more than is absolutely necessary. Assembled mechanism should roll freely.
7. To connect No.16757 Motor Lead and Lug Assembly to No.33578 Motor, remove the Brush Assembly retained by the spring at the left hand side of the motor. Rotate the spring so the loop end is free from the fibre plate. Place stripped end of Motor Lead in loop of spring. Rotate spring back to original position. Replace Brush Assembly. CAUTION! Make sure lead is locked between loop of spring and fibre plate.
8. Fasten No.33578 Motor Assembly to Frame with No. 7281 Screw, #2-56x3/8" Long R.H. used with No.7573 Lock Washer. When the screw is tightened the worm and gear should mesh without binding but with minimum backlash. Should adjustment be necessary, remove metal from pad surface carefully with a smooth file as follows: To bring worm and gear closer together remove from front pad and for wider setting from rear pad.
9. Check unit with 12 Volts, D.C. Power in both forward and reverse motion. DO NOT TEST RUN without lubricating the nylon worm and gear with Lubriplate or a light graphite grease.
10. Attach No.2604 Front Coupler with No.7477 Screw, #0x7/32" R.H.S.T. Position coupler so hook is over center line and will couple with cars easily. Insert one No.7494 Screw, #2-56x3/16" S.T.W.H. through hole in No.6612 Drawbar and screw into hole in rear of frame.

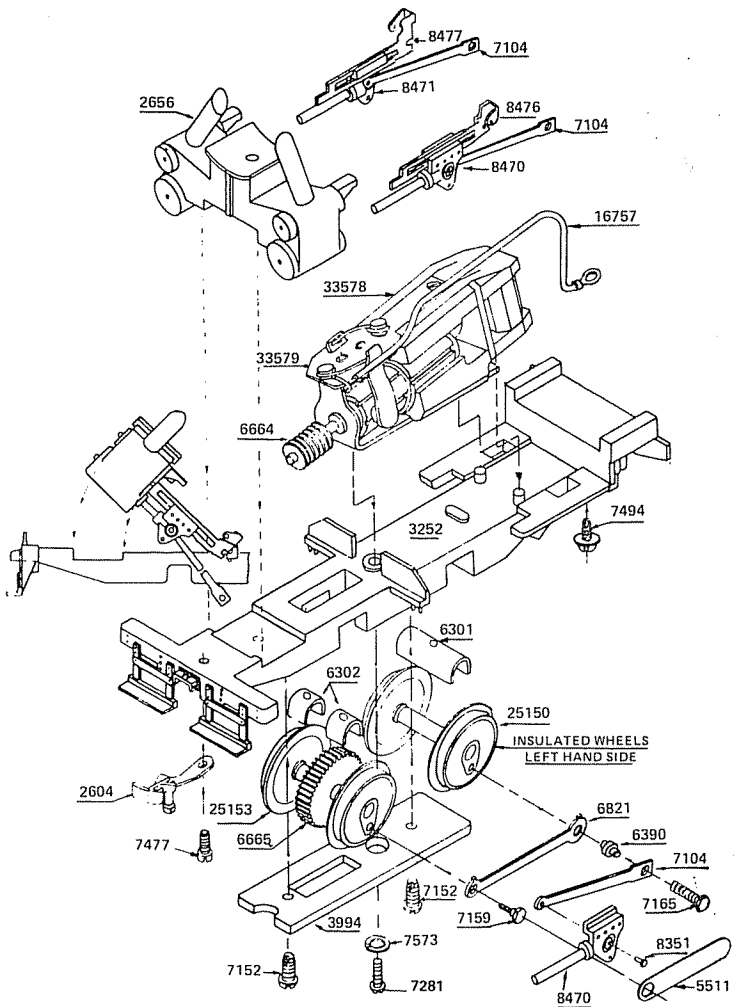

VALVE GEAR ASSEMBLY

1. Check all parts with the replacement parts list. Riveting the valve gear links together requires a reasonable amount of care and study.
2. On a sheet of white paper, place all the valve gear parts just as they will be assembled on the locomotive. The drawing shows the exact relation of the parts to each other. Check your layout over again with the drawing as each part must overlap the other as shown.
3. A few tools will be required for the riveting operation:
 - A small flat block of steel as an anvil.
 - A flat fine cut needle file.
 - A small center punch.
 - A small flat ended punch.
 - A light hammer.
4. To become more familiar with the riveting - start with No. 7104 Main Rods, No.8470 L.H. Side and No.8471 R.H. Side Crosshead Assemblies using No.8351 Crosshead Rivet. Insert a small center punch into the hollow end of the rivet. Tap lightly until the rivet is flared out. With a flat ended punch finish flaring the rivet until it pulls the main rod and crosshead together snugly but not tight. Linkage must operate freely before assembling on locomotive mechanism.
5. After both sides of the main rod and crosshead assemblies are finished, rivet together the No.8458 Eccentric crank and the No.8459 Eccentric rod, using the No.8351 Rivet. Finish both sides before going to the next step, being careful to keep the projecting lug up, thus distinguishing the left from the right side assembly. **IMPORTANT NOTE:** All No.8351 rivets are placed with the head outside. A few extra rivets are supplied for your convenience.
6. Left Side — Rivet No.8459 to No.8473.
Right Side — Rivet No.8459 to No.8473.
7. Left Side — Rivet No.8473 to No.8474.
Right Side — Rivet No.8473 to No.8474.
8. Left Side — Rivet No.8474 to No.8475.
Right Side — Rivet No.8474 to No.8475.
9. Left Side — Rivet No.8475 to No.8478.
Right Side — Rivet No.8475 to No.8478.
10. Left Side — Rivet No.8475 to No.8472.
Right Side — Rivet No.8475 to No.8472.
11. Left Side — Rivet No.8472 to No.8470.
Right Side — Rivet No.8472 to No.8471.
12. Rivet the No.8473 Reverse Links to No.8476 L.H. and No.8477 R.H. Crosshead Guide and Reverse Link Hanger. Use No.8351 Short Valve Gear Rivet (see insert drawing).
13. Assemble crosshead and No.8476 L.H. and No.8477 R.H. crosshead guide and reverse link hanger as shown in final mechanism assembly drawing. Small end of guide pointing the same direction as the piston rod.
14. Assemble No.2656 Cylinder Unit and crosshead guides by inserting piston rod in cylinder, followed by the single point end of crosshead guide into the elongated hole above it. Hold completed unit in position over frame and place notched end of crosshead guide between protecting pins at bottom of guide bracket. Check crossheads making certain that they slide freely in the guides. Hold cylinder unit in place temporarily by inserting No.7285 Screw, #2-56x5/8" R.H. through from bottom of frame and secure with a No. 7427 Nut, #2-56 Hex.
15. Remove the No.7165 Main Rod screw from each side of the rear drivers, slip the end of No.7104 Main Rod over No.6390 shouldered bushing. Now with the No.8458 eccentric crank place over the end of the bushing, replace the long hex head main rod screws. The eccentric crank is thus clamped between end of bushing and the underside of hex head screw. The eccentric crank may be set at any angle from 0 degrees to 30 degrees. The 0 degree setting allows a minimum amount of movement of the valve gear. A 30 degree setting allows a maximum amount of movement and also more wear on the valve gear. Insert drawing shows 0 degree angle in dotted line position and 30 degree angle in solid line.
16. Lubricate worm and gear with Lubriplate or any good light grease. Apply a drop of light oil to all other moving parts. Turn locomotive upside down and in this position run-in mechanism for not less than 30 minutes with 12 volts D.C. power. Reverse the direction of rotation one half the run-in period.

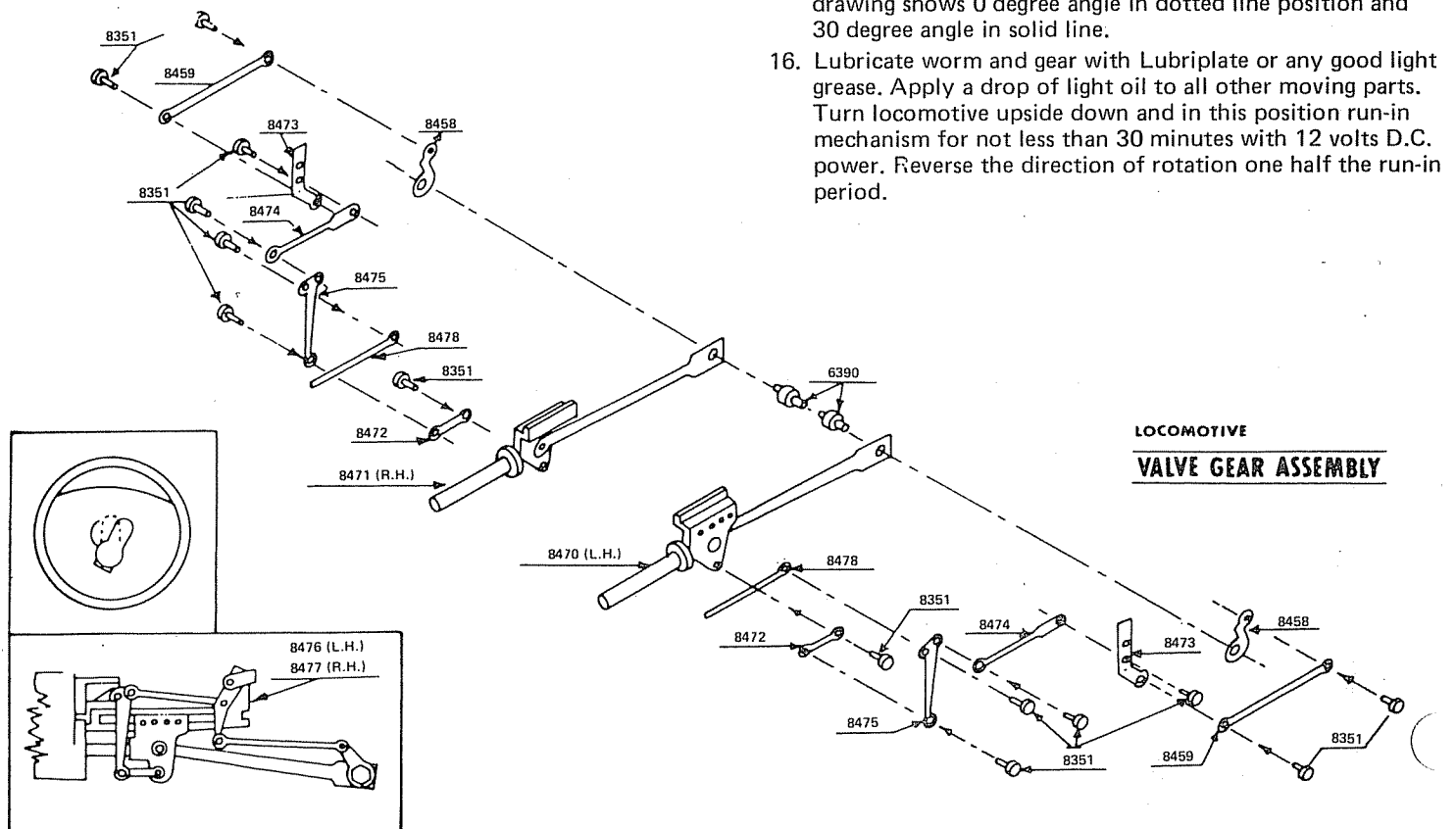

BOILER ASSEMBLY

The Boiler is a one-piece casting with all fittings cast on except the Bell, which is a brass turning. The cab is also one piece. The assembly of this unit is, therefore, simplified and very easy.

Plastic Boiler and attachments are available upon request.

1. Mount No.2428 Cab on No.2312 Boiler with one No.7487 Screw, #2x3/8" S.T. inserted through lug at the top of rear end of boiler and screw in place into the top of the cab. Make sure that the bottom front edge of the cab fits between lug and boiler and seats on protruding sides of the firebox. All flash around top edge of boiler and front edge of cab must be cleaned off carefully for a good fit.
 2. Insert mounting lug on No.8186 Bell into hole in top of boiler as shown in drawing. Place a small block of wood on top of the bell and tap into position.
 3. Cement No.8239 Jewel in Headlight Bracket as indicated on drawing.
 4. The three top No.7694 Handrail Posts on each side of the boiler are started in place with a pair of pliers. Cut the No. 7609 Handrail wire in two pieces 4" long, one for each side of the boiler. At a point one inch (1") from one end make a 90 degree bend using a 1/8" diameter rod as a form, giving a nice radius instead of a sharp corner, also form this end to the contour of the boiler. Insert thru holes in the three posts along side of boiler and entering hole provided in front wall of cab. The formed radius will be at the front of boiler. Thread one of the remaining posts on other end of bend. Insert end of post in the fourth hole, all handrail posts should be lightly tapped home with a hammer. Clip off front end of wire 1/32" below lower post.
 5. Remove No.7427 nut #2-56 Hex temporarily used in mechanism assembly.
- Place completed boiler on frame, making certain that the projecting lugs on the lower edge of the firebox seat properly in the inside edge of firebox cutout. Push boiler back as far as it will go, thus engaging the lugs and locking boiler in place.
7. Insert one No.7285 Screw, #2-56x5/8" R.H., up through frame, cylinder unit and into boiler and screw up snugly. Check and see that the motor lead is over top of motor and not jammed between firebox sides and motor.

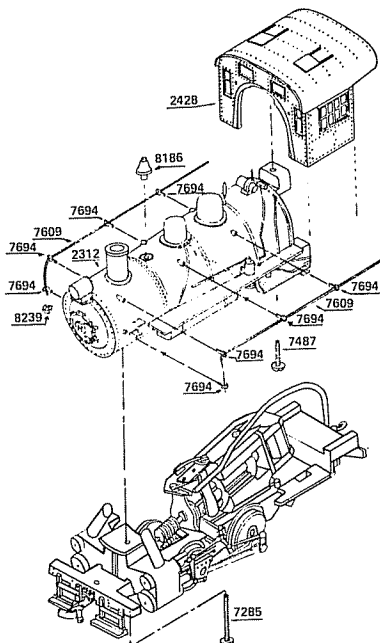

TENDER ASSEMBLY

1. Check all parts with the replacement parts list.
2. Assemble No.2289 Tender Body to No.3273 Frame. Insert two rear lugs on frame into openings on body and press front lug into slot on body.
3. Place No.2601 Coupler in No.2603 Coupler Pocket and insert No.7477 Screw, #0x7/32" S.T.R.H. as shown on drawing. Screw into hole provided on No.3273 Frame. Be sure coupler is under spring tension and moves freely.
4. Install No.34882 Trucks with insulated wheels on the right hand side (opposite side to locomotive insulated wheels). Screw into place with two No.7494 Screws, #2-56x3/16" S.T.W.H.
5. Place No.6612 Drawbar over boss at front end of tender frame, over this place Motor Lead Wire Terminal and secure with a No.7494 Screw, #2-56x3/16" S.T.W.H. The other end of the drawbar slips over the boss at the rear of the locomotive frame, a No.7494 Screw is also used to secure this end.
6. Place No.7922 Coal Pile in position as shown. For a permanent assembly a drop of plastic cement may be used.

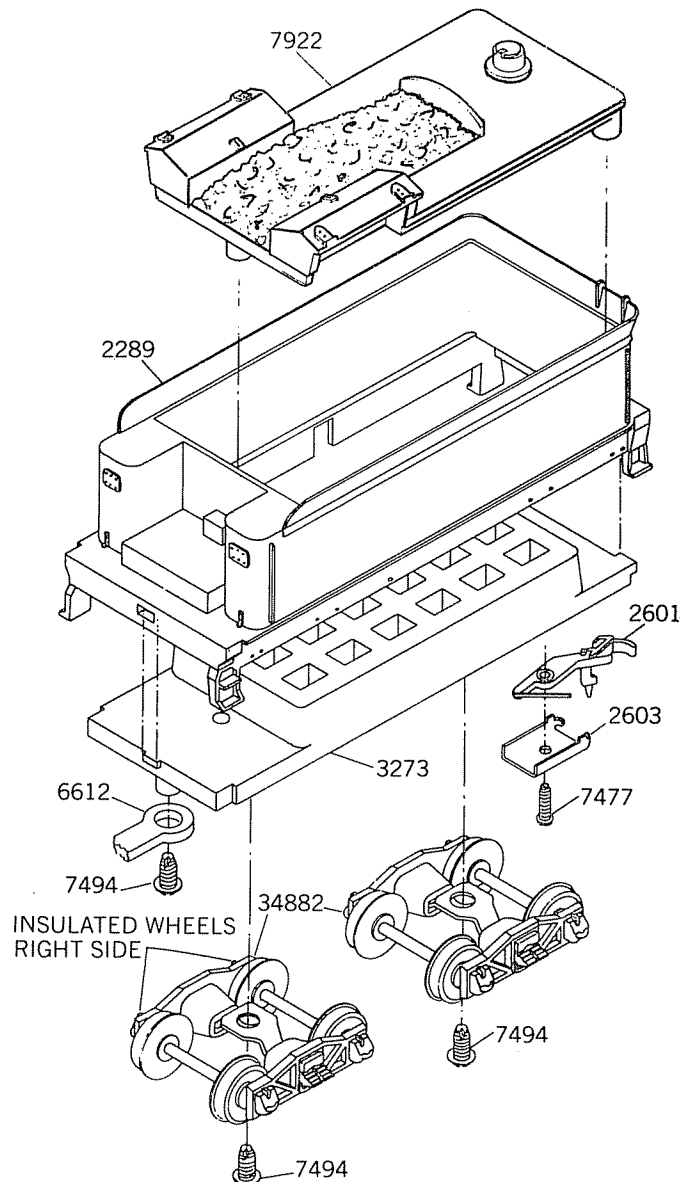

NO. IN KIT DESCRIPTION	PART NO.	UNIT
------------------------------	-------------	------

MECHANISM PARTS

1	Frame, Main Loco	3252
1	Bearing, Long Axle	6301
2	Bearings, Short Axle	6302
1	Wheels and Axle, 50" Flanged with Gear	25153
1	Wheels and Axle, 50" Flanged	25150
1	Retainer Plate	3994
2	Screws, #2-56x3/16" S.T.R.H.	7152
1	Coupler	2604
1	Screw, #0x7/32" S.T.F.H.	7477
2	Side Rods, Plain (.968 centers)	6821
2	Main Rods, (1" centers) straight	7104
1	Crosshead and Piston Rod, L.H.	8470
1	Crosshead and Piston Rod, R.H.	8471
2	Screws, Short Side Rod	7159
2	Rivets, Valve Gear	8351
1	Wrench, #0-80	5511
1	Cylinder Unit	2656
1	Screw, #2-56x5/8" R.H.	7285
1	Nut, #2-56 Hex	7427
1	Motor, Small with 6644 Worm Parts for Above	33578
1	Motor, Small	33579
1	Worm, Nylon, 56P	6644
1	Screw, #2-56x3/8" R.H.	7281
1	Lock Washer	7573
1	Motor Lead and Lug Assembly	16757

VALVE GEAR PARTS

2	Bushings, Main Rod	6390
2	Screws, #0-80x1/4" Hex Head Main Rod	7165
16	Rivets, Valve Gear	8351
2	Eccentric Cranks	8458
2	Eccentric Rods (.608 Centers)	8459
2	Eccentric Rods (.926 Centers Kit No.504-6)	8449
2	Crosshead Links	8472
2	Reverse Links	8473
2	Radius Rods	8474
2	Combination Levers	8475
1	Crosshead Guide and Reverse Link Hanger L.H.	8476
1	Crosshead Guide and Reverse Link Hanger R.H.	8477
2	Valve Rods	8478

NO. IN KIT DESCRIPTION	PART NO.
------------------------------	-------------

BOILER PARTS

1	Boiler, Die Cast	2312
1	Cab, Plastic	2428
1	Screw, #2-56x3/8" S.T.R.H.	7487
1	Bell with mounting lug	8186
8	Posts, Handrail	7694
1	Wire, Handrail (Steel 8" long)	7609
1	Jewel, Headlight	8239

TENDER PARTS

1	Tender Body	2289
1	Frame	3273
1	Truck (Pair)	34882
1	Coupler	2601
1	Coupler Pocket	2603
1	Screw, #0-7/32" S.T.R.H.	7477
1	Coal Pile	7922
1	Drawbar	6612
4	Screws, #2-56x3/16" S.T.W.H.	7494

REPLACEMENT PARTS

See your Hobby Dealer. If he cannot supply them you may order from the factory. Please send check or money order for parts required, plus \$1.00 for postage and handling.

DEFECTIVE PARTS

RETURN PARTS ONLY - NOT COMPLETE MODEL. Any defective part will be replaced at no charge. If complete or partially completed model is returned only the defective part will be replaced, not installed.

Please enclose check or money order for \$1.00 to cover the cost of postage and handling.

MANTUA FULL ONE YEAR WARRANTY

All Mantua Products are thoroughly inspected and tested prior to shipment and are guaranteed to operate satisfactorily and be free from factory defects. If within one (1) year from the date of purchase this product fails due to defect in material or workmanship Mantua will repair or replace it free of charge. This guarantee does not apply to (a) electric bulbs, (b) damage caused by accident, abuse or mishandling, dropping and (c) units which have been subjected to unauthorized repair. To prevent damage in transit please pack securely and return to: Mantua Service, Grandview Avenue, Woodbury Heights, N. J. 08097.

MANTUA

D., INC.
EIGHTS, NEW JERSEY 08097

1/80
55-0005