

English's Model Railroad Supply

(A DIVISION OF BOWSER MFG. CO., INC.)

Assembly Drawing for AAR 40' Steel Box Car

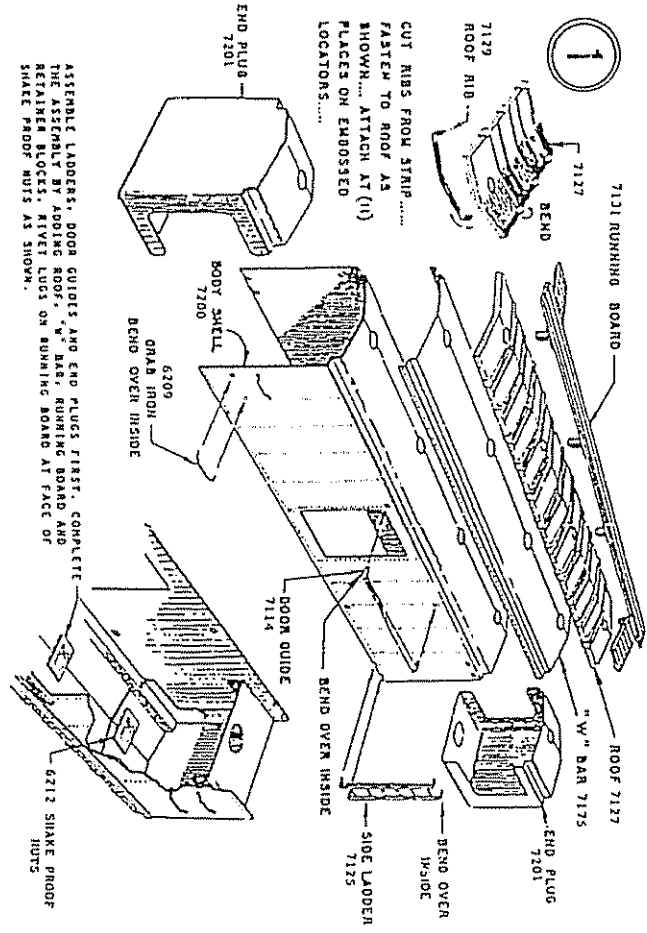

ASSEMBLE LADDERS, DOOR GUIDES AND END PLUGS FIRST, COMPLETE THE ASSEMBLY BY ADDING ROOF, "W" BAR, RUNNING BOARD AND RETAINER BLOCKS, RIVET LUGS ON RUNNING BOARD AT FACE OF SHEET PILE NUTS AS SHOWN.

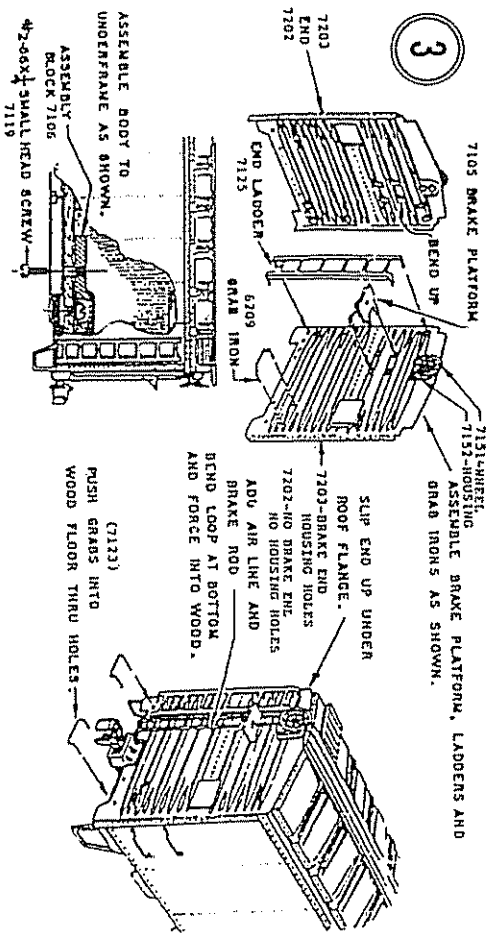

ASSEMBLE BODY TO UNDERFRAME AS SHOWN.
ASSEMBLY BLOCK 7106
#2-66x1/4 SMALL HEAD SCREW 7119

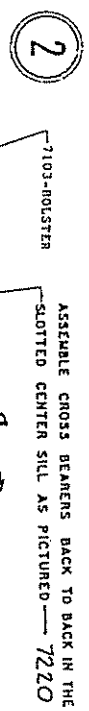

ASSEMBLE COVER PLATES IN HOUSINGS AS SHOWN IN LOWER SKETCH.
Brake rods and air lines not included.

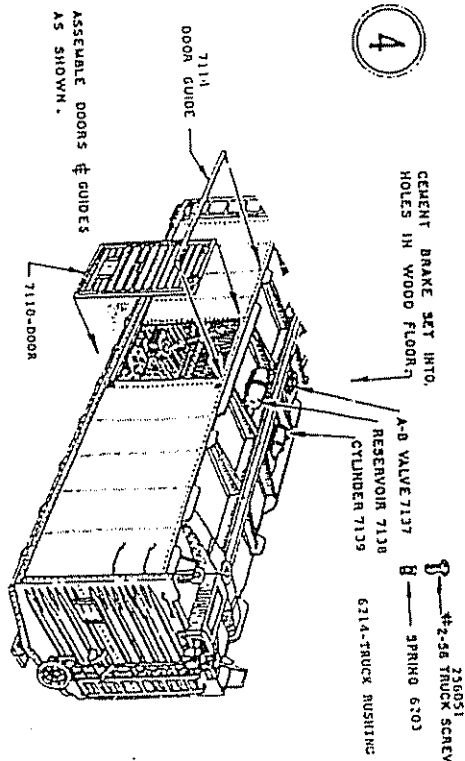

ASSEMBLE DOORS & GUIDES AS SHOWN.

English's Model Railroad Supply

(A DIVISION OF BOWSER MFG. CO., INC.)

Assembly Drawing for 40' Reefer

